

LAB Series Model: EMSGR48C



Refrigeration System

- Bottom mounted, self-contained and fully detachable Blizzard R290 condensing unit uses environmentally friendly, EPA-compliant R290 refrigerant with zero (0) Ozone Depletion Potential (ODP) and three (3) Global Warming Potential (GWP). Blizzard R290 is easily replaceable and requires no on-site brazing.
- Electronically commutated (ECM) fan motors achieve rapid cooling with less energy consumption.
- Full-length air duct ensures optimal cold air distribution.
- Air circulation guard keeps floor vents from obstruction.
- Time-initiated and temperature-terminated auto defrost cycle for seamless operation.
- Large capacity, corrosion-resistant condenser and evaporator coils.
- Self-maintaining, energy-efficient condensate drain pan requires no external drains or electric heaters.
- High performance, auto-reverse condenser fan motor supports compressor ventilation and condenser coil cleaning.
- Pre-wired and ready to plug, 115V/60Hz/1Ph, NEMA 5-15P.

Cabinet Construction

- Heavy duty white coated steel interior / exterior.
- Open spaced interior with no walls between compartments.
- Stainless steel floor interior has rounded corners and detachable drain plug for ease of cleaning.
- 2.5" thick high density polyurethane insulation.
- Four height adjustable screw legs.

Lighting

- Shielded LED bar lighting with on/off switch provides bright, high color illumination at lower heat output.

Doors

- Low emissivity double glass panes reflect UV rays for efficient cooling.
- Black PVC door frames.
- Self-closing with adjustable torsion system for a positive seal.
- Snap-in magnetic door gasket make cleaning and replacement an easy process.
- High strength, die-cast door handles.

Shelving

- Four epoxy coated, steel wire shelves with airflow guard per section.
- Height adjustable stainless steel clips.

Chromatography Features

- Two access ports (one on each side wall) for running lines or cords. Includes heavy duty covers with lockable tabs.
- Duplex GFCI electrical outlet inside cabinet interior provides power for stirring devices and other equipment. Includes water proof cover.

Temperature Control

- Multi-function digital controller with easy to read LED display.
- Factory preset temperature, 35°F. Temperature setting range from 33°F to 54°F.
- Audible overheat protection alarm for compressor and condenser coil.

Options

- Additional shelving.
- 5" or 3" swivel casters with locks on front set.
- 3.5" – 6" height-adjustable and interchangeable legs.
- NAMA certified, NSF compliant Health Timer Lock



Please visit our website for updated Energy Efficiency information

| Ref/ Frz/Dual | Doors | Capacity Cu. Ft. | Shelves | Refrigerant | HP | Power V-Hz-Ph | Amps | Crated Weight | Exterior Dimensions | | |
|------------------|-------|---------------------|---------|-------------|-----|------------------|------|--------------------|---------------------|----------------|---------------------|
| | | | | | | | | | L | D | H* |
| REF | 2 | 50 | 8 | R-290 | 1/2 | 115-60-1 | 5.5 | 524 lbs (238kg) | 53.125" (1349mm) | 32" (813mm) | 80.125" (2035mm) |

(†)Based on evaporating temperature of 23°F (-5°C) & condensing temperature of 131°F (55°C). (►) Product capacity is calculated based on standard industry figures. (✳) Reference plan view for clarification on caster/unit height. If dimensions and capacity are critical, please contact Everest Refrigeration. Blizzard R290 replacement is at the sole discretion of Everest Refrigeration. Specifications subject to change without notice.

CHROMATOGRAPHY REFRIGERATOR SWING DOORS

LAB Series Model: EMSGR48C

DIMENSIONAL DATA

| | | |
|--------------------------|----|------------------|
| External Dimensions | L | 53.125" (1349mm) |
| | D | 32" (813mm) |
| | H* | 80.125" (2035mm) |
| Crated Weight | | 524 lbs. (238kg) |
| Doors/Drawers/Lids | | 2 |
| Max Weight Support (LBS) | | - |

STORAGE DATA

| | |
|------------------------|----|
| Net Capacity Cu. Ft. ▶ | 50 |
| Shelves | 8 |
| Barrels | - |
| 20 oz. Bottles | - |
| 12 oz. Bottles | - |
| 12 oz. Cans | - |
| 8" Mugs | - |
| # of Pans (Top) | - |
| # of Pans (Drawer) | - |
| Dividers | - |
| Trays | - |

ELECTRICAL DATA

| | |
|------------------------|--|
| Voltage | 115-60-1 |
| Full Load Amperage | 5.5A |
| Feed Wires with Ground | 3 |
| Cord Length | 9ft |
| NEMA Plug Type |  NEMA 5-15P |

REFRIGERATION DATA

| | |
|---------------------|--------|
| Compressor Mounting | Bottom |
| Refrigerant | R-290 |
| Compressor HP | 1/2 |
| BTU/HR † | 3563 |

KEY

| | | | |
|----|------------|------|---------------|
| D | Door | R | Refrigerator |
| L | Lid | REF | Refrigerator |
| H | Half Door | F | Freezer |
| FD | Full Door | FRZ | Freezer |
| SD | Solid Door | DUAL | REF/FRZ Combo |
| GD | Glass Door | DR | Drawer |

| | | | | | |
|--|-----------|-------|------|----|------|
|  | Elevation | Right | Plan | 3D | Back |
| | | | | | |

PLAN VIEW



FRONT

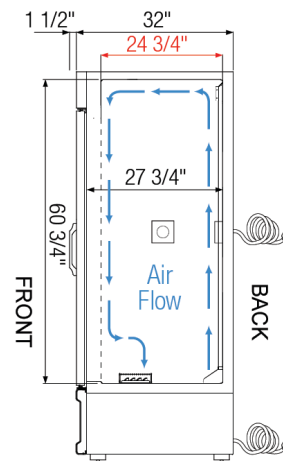

SIDE

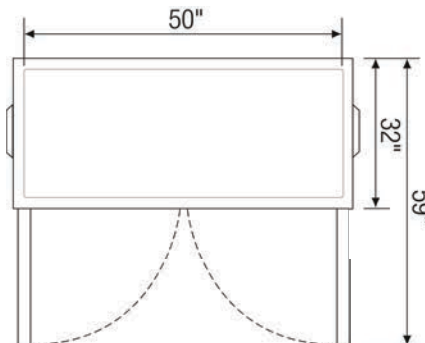

TOP

ACCESSORIES & OPTIONS

| Part Number | Description |
|----------------------------|--|
| Additional Shelving | Contact Everest Refrigeration for more information. |
| AJL03-00 | Interchangeable Leg for Caster (Optional) |
| CASA3-01 | 3" Overall Height Caster Assembly - (2) Front (2) Rear |
| CASA5-01 | 5" Overall Height Caster Assembly - (2) Front (2) Rear |
| HL02-00* | Health timer lock for double door |
| HLK01-00* | Health timer lock key (remote controller) |

(†)Based on evaporating temperature of 23°F (-5°C) & condensing temperature of 131°F (55°C). (▶) Product capacity is calculated based on standard industry figures. (✳) Reference plan view for clarification on caster/unit height. If dimensions and capacity are critical, please contact Everest Refrigeration. Blizzard R290 replacement is at the sole discretion of Everest Refrigeration. Specifications subject to change without notice.